

BL Downlight Pure MS

BL Downlight Pure-MS 240mm 1900/2300lm 16.5/21W 110D 840 WH IP40 550/700mA
Article no.: 722026

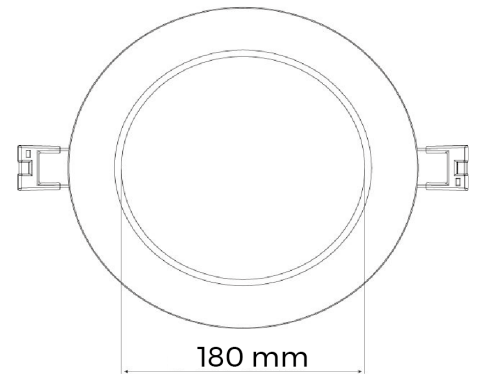

Mounting method



Degree of protection (IP)

TENDER TEXT

LED recessed downlight round, 1,900 or 2,300 lumens, 16.5 or 21W, 110° direct beam, CRI >80, 4,000 Kelvin, IP40, IK05, protection class III, dimmable, white aluminum housing, without power supply, with motion sensor and through-wiring box, dimensions: D 240mm x H 24mm BL Downlight Pure MS Article 722026 LED Einbau downlight - operating device yes, compact design with high-quality, White coated Aluminium frame; best light quality and homogeneous, symmetrisch light distribution across the entire light emission surface; UV-resistant yes, Protection class IP40, Shock resistance IK05, Luminous flux, Connected load 21 W, Luminaire luminous efficacy, Color rendering >80, Light color White, Color temperature 4000 K, Beam angle 110°, Dimensions: 240.0 mm x 240.0 mm x 24 mm

TOP-FEATURES

- //_ Plug&Play connection
- //_ With motion sensor
- //_ Compact design with high-quality aluminum



BL Downlight Pure MS

BL Downlight Pure-MS 240mm 1900/2300lm 16.5/21W 110D 840 WH IP40 550/700mA

Article no.: 722026



MECHANICAL DATA

Material housing	Aluminium
Colour housing	White
Width [mm]	240.0
Length [mm]	240.0
Height/depth [mm]	24
Installation diameter [mm]	227
Outer diameter [mm]	240
Mounting method	Einbau
UV-resistant	yes
With movement sensor	yes
With light sensor	nein
Lamp type	LED nicht austauschbar
Type of fastening	Retaining springs
Impact strength	IK05
Degree of protection (IP)	IP40
With lamp	yes
Control gear included	nein

ELECTRICAL DATA

Protection class	III
Voltage type	DC
Nominal voltage [V]	27 - 30
Nennstrom [A]	0,7
Max. system power [W]	21

LIGHT TECHNICAL DATA

Beam angle [°]	110
Colour rendering index CRI	>80
Light distribution	symmetrisch
Colour temperature [K]	4000
Colour of light	White
Colour consistency (McAdam ellipse)	SDCM4

TEMPERATURE TECHNICAL DATA

Impact strength	IK05
-----------------	------

PACKAGING INFORMATION

EAN	4250716949933
Article no.	722026
Net weight [g]	520

BL Downlight Pure MS

BL Downlight Pure-MS 240mm 1900/2300lm 16.5/21W 110D 840 WH IP40 550/700mA

Article no.: 722026



Gross weight [g]	601
Customs tariff number	94051190
Net width [mm]	240.0
Net height [mm]	24
Net length [mm]	240
State of origin	CN

NECESSARY ACCESSORIES

Article	Article no.
LED DRIVER 220-240V CC 700mA 27-45VDC ON/OFF	729158
LED DRIVER 220-240V CC 550mA 27-45VDC ON/OFF SW	729167

SAFETY INFORMATION: Read the safety and installation instructions carefully and completely before commissioning. The operating instructions can be found at: www.better-light.at

DISCLAIMER OF WARRANTY: The technical information corresponds to the status at the time of printing and have been worked out to the best of our knowledge. However, errors and printing errors are reserved. Make sure that you always use the latest version of the data sheets. The latest data sheet can be found at: www.better-light.at

BL Downlight Pure-MS Einbauleuchte 240mm 2300lm 21W 110D 840 WH IP44 MS 700mA



Artikelnummer: 722026

SENSOR DATEN

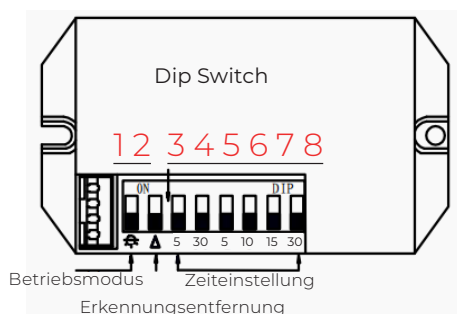
Spannung [V]	200 - 240V/AC
Frequenz [Hz]	50/60 Hz
Betriebsmodus	Nacht- (<15LUX) und Ganztagsmodus
Erkennungsentfernung [m]	4m und 8m ±2m
Zeiteinstellung [s; min]	5 s; 30 s; 5 min; 10 min; 15 min; 30 min
Erfassungswinkel [°]	Wand 100°; Decke 360°
Max. Last [W]	10 x 15 W
Einbauhöhe [m]	1,8 - 4
Stromverbrauch	≤0,5 W
Umgebungsbedingungen	-20~+42; < 93 % RH



DIP SWITCH EINSTELLUNG

1	Betriebsmodus		OFF: Ganztagesmodus ON: Nachtmodus (< 15 Lux)
2	Erkennungsentfernung		OFF: 8m ON: 4m
3-8	Zeiteinstellung	5 30 5 10 15 30	5s (±3s), 30s (±5s), 5min (±15s), 10min (±30s), 15min (±1min), 30min (±2min) Wenn mehrere Schalter auf ON sind, gilt die kürzeste Zeit

